



GML 2032 Microphone Preamp / Parametric Equalizer

The Model 2032 Microphone Preamp / Parametric Equalizer is a single-channel, multi-input device for high-resolution studio and remote applications. Incorporating the renowned 8300 preamp and reference-standard 8200 equalizer, the Model 2032 inherits over thirty years of GML engineering excellence. This transparent class-A discrete design with internal supply delivers reliability, musicality, and precision.

Owner's Manual

Version 1.0
August, 2004

All materials herein © George Massenburg Labs, LLC.

GML, LLC.
Franklin, TN USA
615.790.9946 (ph)
www.massenburg.com

INTRODUCTION

Combining the features of the GML flagship 8200 Parametric Equalizer and 8300 Transformerless Microphone Preamplifier, the Model 2032 embodies the legendary detail and accuracy for which GML is renowned. The power and functionality of these revolutionary processors is further coupled with the addition of a front panel musical instrument input, two position high-pass filter, front panel phantom and phase switching, and flexible routing options while maintaining the GML standard of performance and transparency. These advanced circuits, envisioned by George Massenburg, have benefited from over 30 years of research, limited manufacturing, critical listening analysis, widespread usage by demanding industry professionals, and continuous evaluation by the GML Engineering Department.

FEATURES

The GML Model 2032 Microphone Preamplifier / Parametric Equalizer derives its power and flexibility in large part from its features:

- All-discrete, Class-A design; no integrated circuits to compromise the audio path
- DC-servo and premium-grade film coupling; no interstage capacitors to add distortion or degrade over time; no tantalum electrolytic, ceramic, or aluminum electrolytic capacitors in the signal path*
- Transformerless; precision electronically balanced inputs
- Designed with GML 9202 (single) and GML 8501 (dual-differential) low-noise, low-distortion, wide dynamic range, wide bandwidth precision discrete opamps
- DC-servo stabilized direct-coupled output
- Multi-input format: MIC or MI (front panel musical instrument)
- Wide gain range (10 dB to 75 dB) available on both inputs
- Precision *Gain* switch: 65dB range in 5dB steps
- Continuously variable preamplifier *Fine* gain control, +/-5dB
- Four-band fully parametric equalizer
- Low-frequency and High-frequency Shelf mode capability

- Flexible routing: Single-Channel, Independent, Inline Insert configurations
- High-pass *Filter*, selectable 40 Hz, flat, 100Hz
- Front panel *Phantom* and *Phase* illuminated switches
- Front panel *EQ IN* and *Insert* illuminated switches
- Overload (OL) indication LED
- Power status LED
- Low-noise, highly regulated internal linear power supply
- Modern surface-mount construction, yielding maximum precision, manufacturability, and reliability
- No internal signal interconnects; high-quality signal relay switching
- Carbon-film and conductive-plastic custom precision potentiometers, manufactured to GML exacting standards
- Multi-colored knobs, GML standard
- Stylish and durable black-anodized aluminum front panel
- Rugged chassis; black powder-coat finish over aluminum
- Reverse-anodized front panel legend, much more permanent than ink or paint processes
- Baked-on epoxy paint silkscreen rear panel legend
- Quality PCB manufacturing, assembly, and chassis construction

*Direct-coupled input option only. Standard production units ship with a phantom-blocking two-pole HPF in the Preamp input, which include high-quality capacitors of both aluminum and tantalum dielectric materials. All Specifications were developed and confirmed using production units. Contact GML for further information.

OPERATION

The Model 2032 Microphone Preamplifier / Parametric Equalizer offers exceptional flexibility and sonic accuracy when dealing with a variety of signal sources and conditions. Allowing quick adjustment of any critical parameter, the operation of the Model 2032 remains straightforward despite an extensive feature set. Indeed, a reduction in apparent complexity is achieved by taking a building-block approach to operational analysis.

I. Preamplifier

The preamplifier section of the Model 2032 Microphone Preamplifier / Parametric Equalizer is based on the gain stage of the Model 8300 Transformerless Microphone Preamplifier, though there are some design changes and a few additions to expand its capabilities further than is realized in the highly specialized Model 8300 mic preamp.

Two input formats are accommodated on the Model 2032: an Input XLR connector is provided on the back panel for microphone input, while the front panel sports a 1/4" unbalanced musical instrument connector. Input signal selection is determined by the *Source* toggle switch.

The microphone input of the Model 2032 is an exact copy of the Model 8300 input circuitry, complete with 48V phantom power and subsequent 2-pole phantom filter. Unlike the Model 8300, the phantom power switch is conveniently located on the front panel and is illuminated to warn the user that phantom power is ON. The MIC input is precision electronically balanced, 1k Ω nominal input impedance, with tremendous dynamic range, remarkably low noise, fast slew rate, and wide bandwidth.

Adding to the Model 2032 input options, the front panel MI input extends the sphere of application to the realm of the oft-neglected musical instrument. This high impedance unbalanced input (1M Ω nominal) offers low noise and low distortion, plus a wide dynamic range and ruler-flat extended frequency response to outclass common instrument inputs. Especially useful for recording bass or electric guitar, this input can also be used for a variety of other unbalanced sources such as electronic keyboards, samplers, etc.

As previously mentioned, the input signal for the Model 2032 is selected on the *Source* switch, located near the left corner of the front panel. Only one source may be active through the channel at a time; however, signals may be present at the other inputs since the source select function does not ground unused inputs (*see Specifications page of this manual for separation figures*). Phantom powering may remain On, if necessary, when switching between input sources without damage to other input devices since the phantom supply does not reach the or MI input. It is, however, recommended that the phantom power be turned Off when not in use to preserve power supply efficiency and eliminate possible DC pops when changing input source selection.

A particularly wide range of gain settings (10dB through 75dB of gain) is available for both preamplifier inputs of the Model 2032. This feature accommodates a broad array of input signals, from extremely "hot" microphone inputs to extremely "low" MI inputs, which are often neglected by professional peripheral audio processing devices. Indeed, the minimal 20dB of gain found in most microphone preamplifiers can be excessive in certain circumstances, and decreases the possibility of optimized gain staging. By the same token, real-world MI signals often require more than the typical 10 dB of gain commonly accorded them.

A combination of the rotary *Gain* switch and *Fine* potentiometer is used to control the gain setting of the preamplifier section, with the overall gain of the preamplifier calculated by adding the two control values. The *Gain* switch allocates between 15dB and 70dB of gain in precise 5dB steps, using a combination of discrete resistors for the ultimate in accuracy, stability, durability, and sonic integrity. Providing +/-5dB of continuously variable gain, the *Fine* control adds elasticity to gain setting.

Incorporated into the preamplifier section, the *Phase* switch activates a relay just before the balancing circuit of the preamp. No signal is present at the front panel *Phase* switch--it is merely a relay control and LED indicator voltage. Engaging this switch reverses the phase of the input signal, akin to swapping pins 2 and 3 on the Input XLR. In the case of the MI input, the *Phase* function will change the absolute polarity of a given input signal.

II. Filter

Immediately following the preamplifier section of the Model 2032 is an extremely useful and transparent high-pass filter (HPF), which has three optional settings: 40Hz roll-off, flat response, or 100Hz roll-off. Designed for maximum clarity and musicality, this active second order Butterworth high-pass filter is implemented with premium-grade SMD film capacitors, precision resistors, and a pristine GML 9202 discrete opamp. Passband response is maximally flat for both the 40Hz and 100Hz selections, while the Model 2032's ruler-flat frequency response is preserved in the "flat" setting. A second-order high-pass filter, this circuit creates a -12dB per octave roll-off below the corner frequency, an appropriately flexible and powerful function since many engineers use the low-frequency band of a fully parametric equalizer--a Model 8200, for instance--in shelf mode as a high-pass filter of sorts.

The Insert Out XLR signal is taken directly from the HPF output and is always active, regardless of the *Insert* switch setting. As with all Model 2032 sections, this stage exhibits extremely low noise and distortion, wide bandwidth, and dynamic range, and utilizes precise DC-servo coupling.

III. Parametric Equalizer

The EQ section of the Model 2032 Microphone Preamplifier / Parametric Equalizer offers precision and adaptability when sculpting the response of any source. Its operational characteristics, duplicated from the Model 8200 Parametric Equalizer, have been honed through many years of use in the most critical recording and mixing situations and have proven both reliable and remarkably accommodating.

The basis of the parametric design topology, in general, specifies control over not only gain or attenuation, but also over both frequency and "Q" factor in multiple user-defined bands. In the case of parametric equalization, "Q" is defined as the center frequency of the alteration (whether gain or attenuation) divided by the bandwidth of that alteration. It follows, then, that low values of "Q" affect a wide range of frequencies around the cut or boost, while high values of "Q" specify a narrow slope around the center frequency.

Another important aspect of true parametric equalization, as embodied in the Model 2032 equalizer section, is the existence of overlapping frequency bands, which provide great precision and flexibility.

Specifically, this parametric equalizer provides complete control over a wide frequency range and "Q" setting, along with 15 dB of cut or boost on four individual bands, with the front panel controls for frequency and "Q" mounted concentrically. The addition of the "Q" characteristic empowers the user to maintain precise and musical control over the tonal attributes of the spectrally processed signal.

The availability of up to 15 dB of gain or attenuation is significant, affording the user unprecedented control from minute adjustments to dramatic alterations over completely flexible overlapping multiple bands. Thus, it is possible to achieve almost any particular "sound" that is desired, no matter if the goal is a subtle modification or an audible coloration effect.

Front panel controls for the Model 2032 equalizer section include an illuminated in/out pushbutton switch plus four color-coded bands with amplitude and dual-concentric frequency and "Q" potentiometers. The amplitude pots are continuously variable between +15 dB and -15 dB, with highly accurate 0 dB settings. Each band offers a wide array of frequencies to select on the outer knob of the dual-concentric potentiometer, with a good deal of overlap between bands to accommodate almost any combination of cuts and boosts. The Low and High bands offer counter-clockwise detents for shelving curves in addition to the variable "Q" values from 0.4 to 4 found in the other two bands--all on the central knobs of the dual-concentric potentiometers. Frequency markings can be found along the inner, larger ring of numbers, while the outer, smaller numbers encircling the dual-concentric potentiometer denotes "Q" value.

IV. Insert

A portion of the Model 2032's allure is the flexibility accorded the user in determining the signal routing of the preamplifier and equalizer sections. This functionality is incorporated in the front panel *Insert* control, an illuminated pushbutton switch that activates a precious-metal contact signal relay.

Specifically, the *Insert* function allows the user to configure the Model 2032 for Single Channel, Independent, or Inline Insert operation (see [Configuration illustration](#)). Single Channel operation feeds the preamplifier output—post-HPF—directly to the equalizer input. Independent operation allows the preamplifier and equalizer to be used on separate signal sources simultaneously, where the Insert Out XLR provides the preamplifier output and the Insert In XLR sources the equalizer input signal. Essentially a special case of the Independent configuration, Inline Insert operation places an external device—possibly a Model 8900 Dynamic Gain Control—between the preamplifier and equalizer sections of the Model 2032. The external device must have analog input and output to interface with the analog-only architecture of the Model 2032.

In all cases, the Output XLR of the Model 2032 is the direct-coupled DC-servo corrected output of the equalizer stage, while the Insert Out XLR carries the direct-coupled DC-servo corrected output of the preamplifier stage, post-filter. There is, therefore, no dedicated output buffering stage; nor is there a master output level control.

Unused inputs and outputs need not necessarily be disconnected from the Model 2032 when de-selected. Indeed, both outputs always transmit signal, given an appropriate input. Neither of the XLR inputs (Input, Insert In) short to ground when not in use. Leaving a 1/4" connector in the MI jack with MIC selected will not adversely affect either the Model 2032 or the external musical instrument. The MI input, however, does short the signal pin (tip) to ground when no connector is inserted, regardless of the position of the *Source* switch.

V. Overload (OL)

In light of the considerable amounts of gain available in both the preamplifier and equalizer sections of the Model 2032 Microphone Preamplifier / Parametric Equalizer, the OL (overload) indicator LED provides an essential metering function. This peak detection meter monitors both the preamplifier and equalizer outputs to preemptively warn of possible signal overload, regardless of the configuration selected on the *Insert* control. It should be noted that although this warning LED is triggered at 24dBu from either aforementioned signal, actual clipping throughout the Model 2032 is not experienced until approximately 27.5dBu, thanks to the extended headroom of GML 9202 discrete opamps.

MODEL 2032 FRONT PANEL DIAGRAM

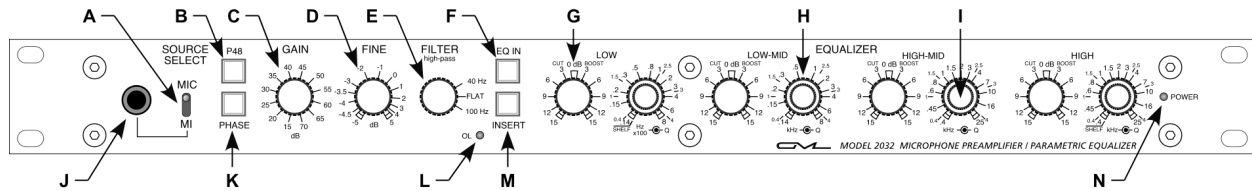

- A. *Source* determines which input the preamplifier section utilizes, either MIC or MI.
- B. *P48* applies 48V Phantom power to pins 2 and 3 of the mic INPUT XLR.
- C. *Gain* sets the coarse gain in precise 5dB steps, from 15dB to 70dB.
- D. *Fine* provides a continuously variable amount of gain, from -5dB to $+5\text{dB}$.
- E. *Filter* regulates the high-pass filter mode of operation, optionally 40Hz, flat, or 100Hz.
- F. *EQ IN* engages the parametric equalizer. No signal is present at the switch; it merely controls a high quality signal relay.
- G. *Cut/Boost* adjusts the amount of gain or attenuation for each equalizer band with a guaranteed 0dB center position.
- H. *Frequency* (outer ring) establishes the center frequency for each equalizer band. Lower frequencies are counter-clockwise while higher frequencies are clockwise.
- I. *Q* (inner knob) appoints the sharpness of a given cut/boost for each equalizer band. Wider peaks/dips are counter-clockwise while more narrow peaks/dips are clockwise. LOW and HIGH bands provide a SHELF mode of operation at the full-CCW detent.
- J. The MI input jack furnishes a convenient unbalanced high impedance input. Tip is “hot”, sleeve is common; tip is shorted to common when no plug is inserted to minimize noise.
- K. *Phase* reverses the preamplifier input signal polarity. No signal is present at the switch; it merely controls a high quality signal relay.
- L. The overload (OL) indicator monitors both the preamplifier and equalizer outputs to warn of possible signal overload. This peak-responding LED is triggered at $+24\text{dBu}$, several dB below actual clipping.
- M. *Insert* splits the equalizer input from the preamplifier output for Independent or Inline Insert configurations. No signal is present at the switch; it controls a high quality signal relay.
- N. The POWER status LED indicates the presence of appropriate AC mains voltage at the rear panel IEC inlet and correct internal DC supply operation.

MODEL 2032 BACK PANEL DIAGRAM

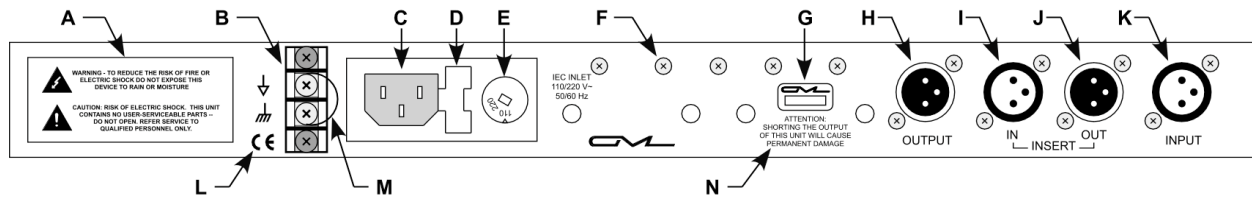

- A. City of Los Angeles, UL, and CE standards require these safety statements.
"WARNING – To reduce the risk of fire or electric shock do not expose this device to rain or moisture."
"CAUTION: Risk of electric shock. This unit contains no user-serviceable parts—do not open. Refer service to qualified personnel only."
- B. The Grounds terminal block gives a common point of continuity to the electronics ground (upper) and the chassis ground (lower). Normally these terminals are tied together with the Ground Strap.
- C. An IEC-type socket provides connection to AC mains power (50 / 60 Hz) via an external power cable. A 6-ft. power cable ships standard with all new units.
- D. Protecting both the power supply fuse and a spare, the safety-interlocking Fuse Holder prevents fuse removal with an IEC plug inserted. Replace with 500mA (110V) or 250mA (220V) Slo-Blow 250V-rated fuse (5mm x 20mm package). *NOTICE: Repeated fuse failure may indicate internal fault. Request service as per Contacts section of this manual.*
- E. Allowing worldwide operation, the Voltage Select switch sets the internal power supply for the correct AC mains line voltage, either 110V or 220V. Gently rotate the switch using a small flat-head screwdriver; the voltage setting is indicated by the small triangle. *WARNING – A mismatch between AC line voltage and setting of the Voltage Select switch may cause permanent damage.*
- F. Internal supply voltage regulator mounting screws should NOT be shorted nor loosened, as this could impair unit performance and/or cause irreversible damage.
- G. Uniquely assigned, the GML Serial Number Tag contains a permanent imprint of the serial number.
- H. The Output XLR provides a professional interconnect to external devices. DC Servo corrected, direct coupled, and unbalanced (pin 2 "hot"), this yields the equalizer output.
- I. Active when *Insert* is engaged, the Insert In XLR is a balanced feed to the equalizer input.
- J. Regardless of *Insert* status, Insert Out monitors the preamp output, post-filter. This XLR is DC Servo corrected, direct coupled, and unbalanced (pin 2 "hot").
- K. The Input XLR applies signal to the preamplifier when MIC is selected on the *Source* switch.
- L. CE (European Electromagnetic Compatibility) marking indicates full compliance with EN 55013:1990 (Electromagnetic Disturbance, Sects. 3.2, 3.5) and EN 55020:1988 (Electromagnetic Compatibility, Sects. 4.3, 5.4, 6.2, 7.0, 8.0).
- M. The Ground Strap normally connects electronics ground and chassis ground; however, in certain situations it may be advantageous and/or necessary to keep these ground references independent (to eliminate ground loops in some installations, for instance).
- N. An Output Warning notice reminds users of the inherent danger and permanent damage associated with shorting the output. Normally, pin 2 is wired as the "hot" output pin.

SPECIFICATIONS*

INPUT

Input Impedance
Mic: 1 k Ω balanced
Insert In: 20 k Ω balanced
MI: 1 M Ω unbalanced (tip "hot")

CMRR, 20 Hz to 20 kHz¹
Mic: >80 dB
Insert In: >50 dB

CMRR, 100 Hz and 10 kHz
Mic: >80 dB
Insert In: >40 dB

Maximum input before clipping²
Mic: +17 dBu
Insert In: +21 dBu
MI: +8.5 dBu

THROUGHPUT

PREAMPLIFIER³

MIC INPUT

-0.1 dB / +0.002 dB, <10 Hz to >200 kHz⁴
-0.01 dB / +0.002 dB, 20 Hz to 40 kHz
-3 dB at 310 kHz and <<10 Hz⁵
<0.0025% Harmonic distortion at +20 dBu, 20 Hz to 30 kHz⁶
<0.0019% Harmonic distortion at +20 dBu, 20 Hz to 20 kHz, averaged
<0.006% SMPTE Intermodulation distortion at +10 dBu⁷
<-120 dBu Equivalent Input Noise⁸

MI INPUT

+/- 0.1 dB, <10 Hz to 30 kHz
-0.01 / + 0.07 dB, 40 Hz to 15 kHz
-3 dB at 185 kHz and <<10 Hz
<0.09% Harmonic distortion at +0 dBu, 20 Hz to 30kHz⁹
<0.08% Harmonic distortion at +0 dBu, 20 Hz to 20 kHz, averaged
<0.45% SMPTE Intermodulation distortion at +20 dBu¹⁰
<-112 dBu Equivalent Input Noise¹¹

EQUALIZER¹²

INSERT IN, EQ DISENGAGED

-0.1 dB / +0.002 dB, <10 Hz to 70 kHz
-0.01 dB / +0.002 dB, 10 Hz to 15 kHz
-3 dB at 575 kHz and <<10 Hz¹³
<0.0006% Harmonic distortion at +20 dBu, 20 Hz to 30 kHz¹⁴
<0.00035% Harmonic distortion at +20 dBu, 20 Hz to 20 kHz, averaged
<0.0015% SMPTE Intermodulation distortion at +10 dBu¹⁵
<-98 dBu noise¹⁶

INSERT IN, EQ ENGAGED¹⁷

-0.1 dB / +0.002 dB, <10 Hz to 70 kHz
-0.01 dB / +0.002 dB, 10 Hz to 20 kHz
-3 dB at 625 kHz and <<10 Hz
<0.0025% Harmonic distortion at +20 dBu, 20 Hz to 30 kHz¹⁸
<0.001% Harmonic distortion at +20 dBu, 20 Hz to 20 kHz, averaged
<0.0025% SMPTE Intermodulation distortion at +10 dBu¹⁹
10.4 dB Noise Figure, EQ In vs. EQ Out²⁰

CROSSTALK²¹

Preamp to Equalizer: <-105 dB

OUTPUTS

+27.0 dBu clipping²²
< 3 mV output offset, stabilized by DC servo correction, direct coupled
Wired pin 2 "hot"

Specification Notes

* All tests conducted at the GML laboratory using the Audio Precision System Two Cascade Dual Domain (AP S2C), or else as noted. Unless otherwise specified, all tests include AP S2C residual measurement and were conducted under the following conditions: $R_s=40\Omega$, $R_L=100k\Omega$, <10Hz to >500kHz analyzer bandwidth. GML reserves the right to make changes to these specifications and/or any of its products as it deems necessary. Individual unit performance may vary due to environmental influences, manufacturing variations, and component tolerances.

¹ CMRR determined by calculating the average across a 200-point logarithmic frequency sweep from 20 Hz to 20 kHz. DUT set to 70dB +0dB gain, +20 dBu CMTST signal from AP S2C.

² Clipping as determined by THD+N in excess of 0.1% for Mic and Inseert inputs, 1.0% for MI input. MI clipping, as stated, is independent of gain setting since the MI input buffer clips before the gain stage(s).

³ All PREAMPLIFIER measurements taken from Insert Out XLR, *Insert* switch engaged

⁴ All bandwidth tests conducted at +0.0 dBu DUT output level for 1kHz reference. Measurements are typical across the gain range of the DUT. Default gain settings: 45dB +0dB, Mic and MI; 0dB, Insert (default; no gain control).

⁵ Direct -3 dB measurement using HP 3314A function generator ($R_s=50\Omega$) and Tektronix 2445 150MHz analog oscilloscope ($R_{in}=1M\Omega$, 15pF) unbalanced into $R_L = 20k\Omega$ termination. DUT gain set to 15dB +0dB. The low-frequency -3 dB corner of the Model 2032 exceeds the LF response of the HP 3314A, which has a -3 dB corner at 7 Hz.

⁶ Includes AP S2C residual THD+N of 0.0007% and Analyzer 30 kHz LPF. Test conducted with -25 dBu swept sine, Mic input, 45dB +0dB gain setting. System noise contributes -77 dBu (0.0011%) to this figure.

⁷ Test conducted using AP System One. Measurement includes System One residual IMD of 0.001%. SMPTE/DIN 4:1 signal, 7 kHz and 60 Hz applied at -35 dBu. DUT set for 45dB +0dB gain, Mic input.

⁸ Noise measurement with $R_s=150\Omega$ balanced termination. Specification includes 2nd order LPF at 30 kHz. Theoretical source resistance noise for this bandwidth is -129.1 dBu. Mic input, 70dB +0dB gain setting. Un-weighted.

⁹ Includes AP S2C residual THD+N of 0.0007% and Analyzer 30 kHz LPF. Test conducted with -15 dBu swept sine, MI input, 15dB +0dB gain setting. System noise contributes -85 dBu (0.0044%) to this figure.

¹⁰ Test conducted using AP System One. Measurement includes System One residual IMD of 0.001%. SMPTE/DIN 4:1 signal, 7 kHz and 60 Hz applied at -25 dBu. DUT set for 45dB +0dB gain, MI input.

¹¹ Noise measurement with $R_s=150\Omega$ unbalanced termination. Specification includes 2nd order LPF at 30 kHz. Theoretical source resistance noise for this bandwidth is -129.1 dBu. MI input, 70dB +0dB gain setting. Un-weighted.

¹² All EQUALIZER measurements taken from Output XLR, signal applied to Insert In XLR, *Insert* switch engaged.

¹³ Direct -3 dB measurement using HP 3314A function generator ($R_s=50\Omega$) and Tektronix 2445 150MHz analog oscilloscope ($R_{in}=1M\Omega$, 15pF) unbalanced into $R_L = 20k\Omega$ termination. The low-frequency -3 dB corner of the Model 2032 exceeds the LF response of the HP 3314A, which has a -3 dB corner at 7 Hz.

¹⁴ Includes AP S2C residual THD+N of 0.0007% and Analyzer 30 kHz LPF. Test conducted with +20 dBu swept sine, Insert In. System noise contributes -98 dBu (0.0001%) to this figure.

¹⁵ Test conducted using AP System One. Measurement includes System One residual IMD of 0.001%. SMPTE/DIN 4:1 signal, 7 kHz and 60 Hz applied at +10 dBu to Insert In.

¹⁶ Noise measurement with $R_s=40\Omega$ balanced termination. Specification includes 2nd order LPF at 30 kHz. This figure denotes the residual broadband noise floor, un-weighted. It is important to note that hardware limitations of the AP S2C, especially low-level reading resolution, prevent a more accurate absolute-noise measurement for low-gain DUT settings.

¹⁷ Control settings, all bands: 0dB cut/boost, minimum frequency, minimum Q.

¹⁸ Includes AP S2C residual THD+N of 0.0007% and Analyzer 30 kHz LPF. Test conducted with +20 dBu swept sine, Insert In. System noise contributes -78 dBu (0.001%) to this figure.

¹⁹ Test conducted using AP System One. Measurement includes System One residual IMD of 0.001%. SMPTE/DIN 4:1 signal, 7 kHz and 60 Hz applied at +10 dBu to Insert In.

²⁰ Includes AP S2C Analyzer 30 kHz LPF. <-78 dBu versus -98 dBu noise, un-weighted. Noise Figure is calculated by the root-sum-of-squares method, using the EQ Out state as the voltage noise reference.

²¹ Includes AP S2C residual crosstalk of -140 dB. Test conducted with +10 dBu 1.0 kHz balanced to Mic input, DUT set for 15dB +0dB gain, *Insert* switch engaged, Output signal measured. Equalizer to Preamp crosstalk, Mic to MI crosstalk, and MI to Mic crosstalk could not be determined since the noise floor exceeds crosstalk components.

²² Clipping as determined by THD+N in excess of 0.1% over a 30kHz bandwidth, $R_L = 100k\Omega$. Outputs clip at +25.3 dBu for $R_L = 600\Omega$. *NOTE: Driving loads <600Ω at high signal levels can damage the unit.*

FORM FACTOR

One channel, multi-input, gain, filter, parametric equalizer with insert capability

Preamplifier section

Two inputs: MIC (balanced, XLR), MI (unbalanced, 1/4"; Tip = Signal, Sleeve = Ground)

Input *Source* control: MIC or MI

Gain control: 10dB to 70dB, 5dB steps

Fine control: -5dB to +5dB, continuously variable

Phase switch, illuminated pushbutton: in-phase (LED off), phase reverse (LED on)

P48 switch, illuminated pushbutton: phantom on (LED on), phantom off (LED off)

Filter -- Second-order Butterworth active high-pass filter; 100Hz, flat, 40Hz

Equalizer section

EQ IN switch, illuminated pushbutton: equalizer in (LED on), equalizer out (LED off)

Four bands, fully parametric, continuously variable

1. 15 Hz – 800 Hz, Q of 0.4 – 4.0 or shelving, 15 dB boost/cut
2. 120 Hz – 8 kHz, Q of 0.4 – 4.0, 15 dB boost/cut
3. 400 Hz – 26 kHz, Q of 0.4 – 4.0, 15 dB boost/cut
4. 400 Hz – 26 kHz, Q of 0.4 – 4.0 or shelving, 15 dB boost/cut

Insert switch, illuminated pushbutton: engaged (LED on), disengaged (LED off)

Configurations

1. Single Channel – preamplifier output feeds equalizer input
2. Independent – split operation
3. Inline Insert – external device inserted between preamplifier and equalizer

MI (1/4" phone) – 1 M Ω unbalanced, buffered preamplifier input with MI selected on *Source*

Input (XLR)

1 k Ω balanced bridging, transformerless; microphone input

Preamplifier input with MIC selected on *Source* switch

Insert Out (XLR)

Direct-coupled, DC-servo corrected, unbalanced (pin2=Sig, pins1,3=Gnd)

Preamplifier and Filter output

Insert In (XLR)

20 k Ω balanced bridging, transformerless; line input

Equalizer input with *Insert* engaged

Output (XLR)

Direct-coupled, DC-servo corrected, unbalanced (pin2=Sig, pins1,3=Gnd)

Equalizer output

OL -- Red LED, +24dBu peak indication: monitors preamplifier and equalizer outputs

POWER

Internal linear power supply; +/-28 VDC, +/-18 VDC, +48 VDC

AC line (IEC): 110V/220V select, 50Hz/60Hz

Approximate power consumption: 28W

Separate Ground and Chassis connections at rear

Blue power indication LED

MECHANICAL

19" W x 1.75" H x 10" D rack mount chassis, black anodized aluminum, silver legend

Weight: 11 lbs., approximate; shipping weight may vary

DESIGN

On the surface it is not eminently evident just how much "new" design is represented in the Model 2032 Microphone Preamplifier / Parametric Equalizer. Indeed, the equalizer section has been barely modified from the reference-standard Model 8200 Parametric Equalizer, while the Model 8300 Transformerless Microphone Preamplifier is largely copied in the preamplifier section. The design innovation, however, of the Model 2032 lies, at least partially, in the confluence of these diverse parts into a cohesive and extremely precise whole.

The most notable and noticeable addition to the aforementioned GML legacy products embodied in the Model 2032 is the inclusion of an internal power supply--a first for GML. While the absolute lowest noise performance can best be achieved with an external power supply, this completely original design minimizes the compromises in order to yield the savings in space and cost that can derive from an internal supply topology.

The inclusion of multiple inputs certainly adds to the allure of the Model 2032, where the MI input circuitry represents a welcome addition to the standard microphone input. The Input XLR can even accommodate low-level "line" sources needing 10dB of gain or more, assuming the external device's output can drive the 1k Ω load impedance. Thus, the Model 2032 preamplifier can capably handle a wide array of input sources.

Much akin to the input section of the Model 2020, the preamplifier section of the Model 2032 builds upon and expands the capabilities of the Model 8300. The inclusion of a polarity inversion function (*Phase*) and front-panel phantom switching (*P48*) certainly bolster user-friendliness. Similarly, the *Fine* control adds flexibility by ensuring the ability to find optimum gain staging between 5dB steps, while also allowing instant gain adjustment with near-infinite resolution.

The *Insert* function of the Model 2032 complements the various processing blocks, providing a great deal of versatility. With the press of this button, the preamplifier and equalizer can be split apart for either completely independent operation or for insertion of an external device between them. The front panel capacity to switch between inputs also augments the agility inherent in the Model 2032.

Though the front panel equalizer controls seem very intuitive to the initiated and experienced audio engineer, the circuit design behind these controls is anything but simple and straightforward. The Model 2032 equalizer section features an exemplary balancing circuit in addition to the actual equalization circuits. It is important to keep in mind that all circuits in any device necessarily alter the sonic character of any complex signal, though these colorations have been meticulously minimized in the design of the Model 2032. Therefore, no alteration is required to compensate for the spectral signature induced by the unit itself.

Great care has also been taken--as in all aspects of the GML Model 2032--to select the highest quality components, from the potentiometers on the front panel to the smallest

passive elements. This attention to detail partially elucidates the quality found in the Microphone Preamplifier / Parametric Equalizer. These component choices, coupled with superior design techniques and a proclivity towards innovation, combine to make the Model 2032 a most powerful, flexible, and transparent single channel processor.

Another feature that distinguishes the Model 2032 is its inherent dynamic range. Naturally, this means that the preamplifier and filter sections maintain low-noise, high-headroom, transparent operation under all signal conditions, at any control setting. In the equalizer section, this extended dynamic range allows for the addition of 15 dB of gain in multiple frequency bands simultaneously without even a hint of distortion or loss of detail and authority. This amazing accuracy is due in large part to the GML propensity to design all audio circuits from discrete components. Discrete designs, when executed properly, help to preserve not only sonic integrity and musicality, but also to maintain the widest dynamic range through the entire signal path, thus eliminating many sonic compromises and limitations. Not only do these discrete topologies--and the GML 9202 discrete opamp in particular--sound better than their integrated counterparts, they also offer the ability to design for higher signal levels internally, while also optimizing dynamic range by providing a low noise floor.

An additional benefit of the discrete circuit topology used in the Model 2032 is increased bandwidth. Not only does this significant extension--of both high and low frequencies--provide for more detail and realism; it also ensures a greater degree of linearity in the traditional audio spectrum (20 Hz to 20 kHz) by locating bandwidth poles superceding these commonly-accepted limits. Indeed, the frequency response of the Model 2032 is well within +/- 0.1 dB from below 10 Hz to well above 80 kHz, while the +/- 3.0 dB response exceeds the ability of most audio test apparatus to measure.

Compactness of design affords the Model 2032 distinct advantages, both from a design standpoint and a user perspective. Originally conceived as a project to provide GML processing in an eminently portable form factor for remote recording and non-fixed installations, the Model 2032 bundles a no-compromise preamplifier, filter, and parametric equalizer into a single rack space chassis. Packing an internal power supply--thus obviating the need to transport bulky external supplies--adds to the portability, making it no hassle to setup a rack full of 2032's. From a design viewpoint, locating all processing blocks on one motherboard and taking full advantage of surface-mount technology yields superior reliability and uniformity, while controlling expenses. All internal signal interconnects are eliminated, leaving only hard-wired audio in/out connectors and high-quality relays in the signal path. No hand wiring of audio signal paths is required, thus further reducing cost and improving reliability.

POWER SUPPLY

Integral to the superb quality of all GML products is the power supply, an internal power supply in this case. No piece of electronic equipment can operate as designed without an adequate power supply; however, many contemporary processors do not feature a supply that can provide clean, quiet power without unduly heating the device. The Model 2032 internal supply excels in this respect, maintaining the ability to deftly react to highly transient signal content and extreme circuit actions. While the absolute lowest noise performance can best be achieved with an external power supply, this highly regulated low-noise linear design minimizes the compromises in order to yield the savings in space and cost that can derive from an internal supply topology. Utilizing a custom toroidal power transformer and precision regulators in a new design with meticulous layout, the net difference in preamplifier noise is approximately 1dB, while no increase in noise for the filter or equalizer is discernable. The internal power distribution scheme employed by the Model 2032 is also responsible for preserving the highest audio quality throughout the many circuits of the Microphone Preamplifier / Parametric Equalizer.

Please note: The Model 2032 does not include a power On/Off switch; the unit is "on" when AC line voltage is applied to the rear panel IEC socket. Ensure proper IEC inlet settings (110V / 220V) before applying power to prevent damage.

A NOTE REGARDING NOISE

It is important to keep in mind that the noise performance of the Model 2032 varies with operational settings. An increase in noise is to be expected when switching from the 'EQ Out' state to the 'EQ In' state. The reason for this characteristic is inherent to GML's proprietary design, which places the control before all of the processing bands. This gives GML parametric equalizers two distinct advantages: first, potentiometer noise is attenuated; second, the likelihood of internal overload is extremely remote, if not impossible, even with 15 dB of gain available in each band. Notably, the most dangerous condition for internal overload is experienced when using just a bit of EQ with very high-level input signals. The big difference between GML units and non-GML units comes not only in design topology, but also in component choices. In fact, the GML parametric topology is not really feasible with IC op-amps--they're always noisier than discrettes--and only works with quiet, transparent discrete op-amps such as the GML 9202, which can cleanly handle output signals up to +27.5dBu. One should expect the noise floor to increase proportionally with gain, frequency, and "Q", in accordance with the laws of physics.

TROUBLESHOOTING

Note: *This unit is a highly sensitive device that includes many complex circuits.*

THIS UNIT CONTAINS NO USER-SERVICEABLE PARTS.

Warning: Risk of electric shock if top cover is removed.

In the event of unit operational failure, contact GML Service and Technical Support. Refer to the "Contacts" page of this manual, or for more current contact information, check the web site. Please be prepared to describe in detail the exact problem that the unit is experiencing, including: failure conditions, system signal flow, exact failure manifestation, events and actions leading to the failure, etc. Also, be able to quickly provide contact information and the unit's GML Serial Number.

It is highly recommended that customers do not attempt to troubleshoot their own units or have them serviced at unauthorized repair centers. Opening the case of the unit will break several manufacturing seals and void the GML warranty--these security measures cannot be readily detected nor easily thwarted, and should be respected wholeheartedly. These measures also act to protect GML intellectual property so that GML may continue to design high-end professional audio peripherals.

NOTICES

The following list of notices will help ensure the longevity of the Model 2032.

- Allow 15-20 minutes for DC servo settling after power-on. Operating the unit before the servos settle may cause clicks and pops that can potentially damage speakers and/or other devices.
- The outputs of this unit are DC Servo stabilized, direct coupled, unbalanced and wired pin 2 "hot". Shorting either output (Insert Send, Output) will cause permanent damage.
- This unit contains ESD-sensitive components; handle with care.
- Provide adequate ventilation for the Model 2032. Inordinate heat buildup can cause premature aging of the components in the unit and may lead to operational failures.
- This unit contains no user-serviceable parts: refer service to GML Service only.
- The availability of extraordinary amounts of gain throughout the Model 2032 necessitates careful attention to the OL meter to avoid internal overload and subsequent sonic degradation.
- To avoid potentially large DC pops, switch inputs or Phantom power at minimal *Gain* settings.
- It is recommended that the Model 2032 be left powered-on for fixed installations. Frequent and/or excessive power cycling may shorten the life of this unit.
- Front panel legend markings reflect approximate values, which may vary from unit to unit due to component tolerances, environmental conditions, normal aging, etc. Frequency, gain, and Q accuracy are not specified nor guaranteed for the Model 2032.

CONTACTS

General Information:

GML, LLC.
615.790.1016 (ph)
615.794.4802 (fax)
www.massenburg.com

Service and Technical Support:

GML, LLC.
Franklin, TN
615.790.9946 (ph)
www.massenburg.com

Engineering:

GML, LLC.
Attn: Jeffrey Warren, Chief Engineer
Franklin, TN
615.790.9946 (ph)
email: gmleng@earthlink.net

Pricing/Ordering:

USA Sales Office:

TransAmerica Audio Group
Las Vegas, NV
702.365.5155 (ph)
sales@transaudiogroup.com

Japan Sales Office:

ProMedia Audio
Tokyo, Japan
+813-3-5397-7092 (ph)
marsh@promediaaudio.com

European Distribution:

BEE Distribution
Genva, Belgium
+32-2-653-90-77 (ph)
lbf@skynet.be

OR

Contact your local dealer--visit our online dealer locator at www.massenburg.com

NOTICE OF COPYRIGHT AND OWNERSHIP

All designs, circuit board artwork, front panel artwork, text contained herein and therein, and all other intellectual material is the sole property of George Massenburg Labs, LLC (and/or GML, Inc.). Unauthorized use, distribution, reproduction, etc. is strictly prohibited. GML intellectual property is protected by U.S. and international copyright laws. Violators will be prosecuted to the fullest extent of all applicable laws.

Transfer of ownership of this unit neither confers nor implies any transfer of ownership of the intellectual property, proprietary design, etc. contained herein.

**THIS PAGE IS ONLY A REFERENCE AT THIS TIME. A FINAL REVISION
CONTAINING ALL PERTINENT INFORMATION WILL BE INCLUDED IN FUTURE
RELEASES OF THIS DOCUMENT.**

Credits

Concept: George Massenburg and Jeffrey Warren

Written by: Jeffrey Warren

Diagrams: Jeffrey Warren

Edited by: Jeffrey Warren and George Massenburg

Additional editing: David Robinson, Frank Wire

Technical assistance: Frank Wire, Manny Sanchez, Michael Wilk

ADDITIONAL GML PERIPHERALS

Model 2020 High Resolution Discrete Input Channel

Model 2030 Mastering Dynamic Gain Control, Series III

Model 8200 Parametric Equalizer, Series II

Model 8300 Transformerless Microphone Preamplifier

Model 8355 Power Supply

Model 8900 Dynamic Gain Control, Series III

Model 9015 Power Supply

Model 9500 Two Channel 5-Band Parametric Mastering Equalizer

HRT 9100 Mixer

HRT 9145 Multi-Output Power Supply

Model 9550 Two Channel Digital Noise Filter

Model 9560 Digital Noise Filter w/ Macintosh Controller

For ordering information, contact:

USA Sales Office:

TransAmerica Audio Group
Las Vegas, NV
702.365.5155 (ph)
sales@transaudiogroup.com

Japan Sales Office:

ProMedia Audio
Tokyo, Japan
+813-3-5397-7092 (ph)
marsh@promediaaudio.com

European Distribution:

BEE Distribution
Genva, Belgium
+32-2-653-90-77 (ph)
lbf@skynet.be

OR

Contact your local dealer--visit our online dealer locator at www.massenburg.com

CONFIGURATION I.

Single Channel Operation

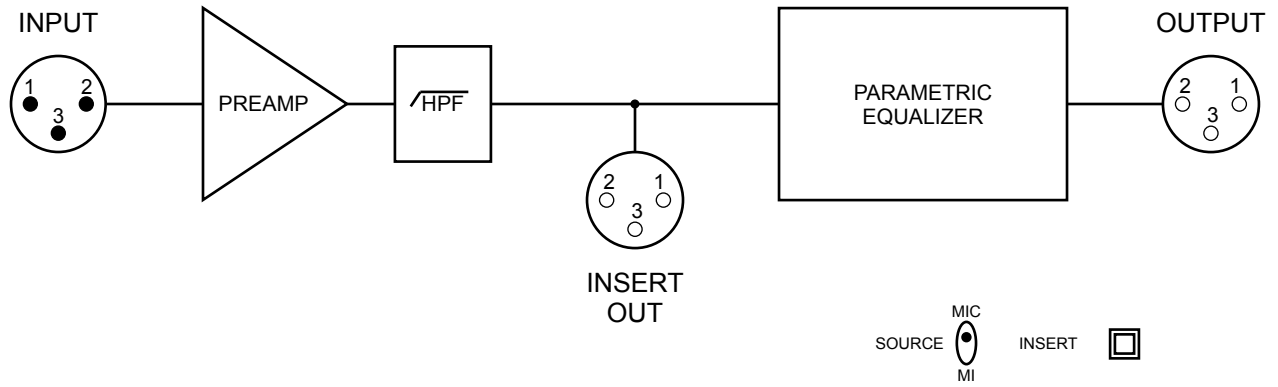

CONFIGURATION II.

Independent Operation

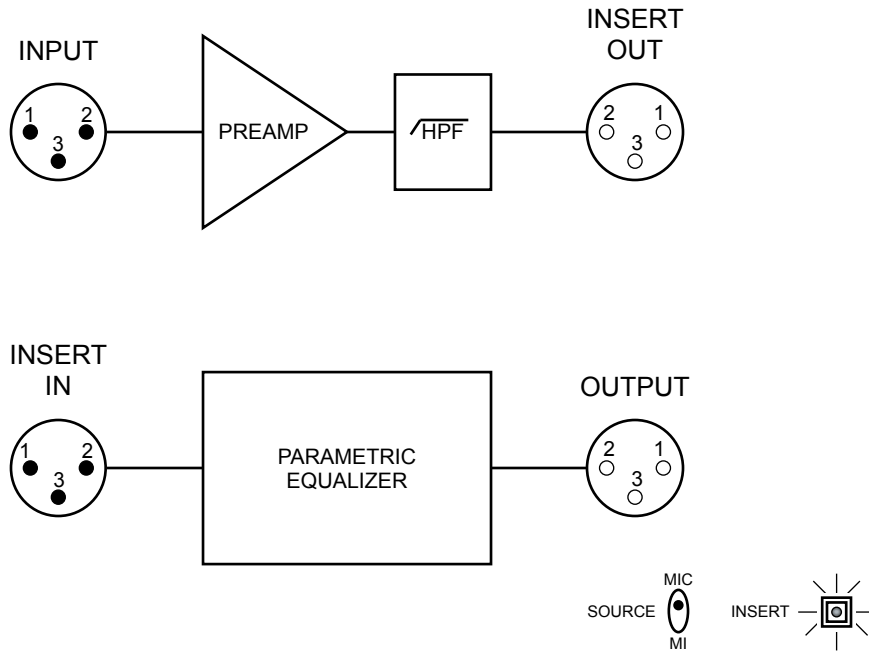

CONFIGURATION III.

Inline Insert Operation

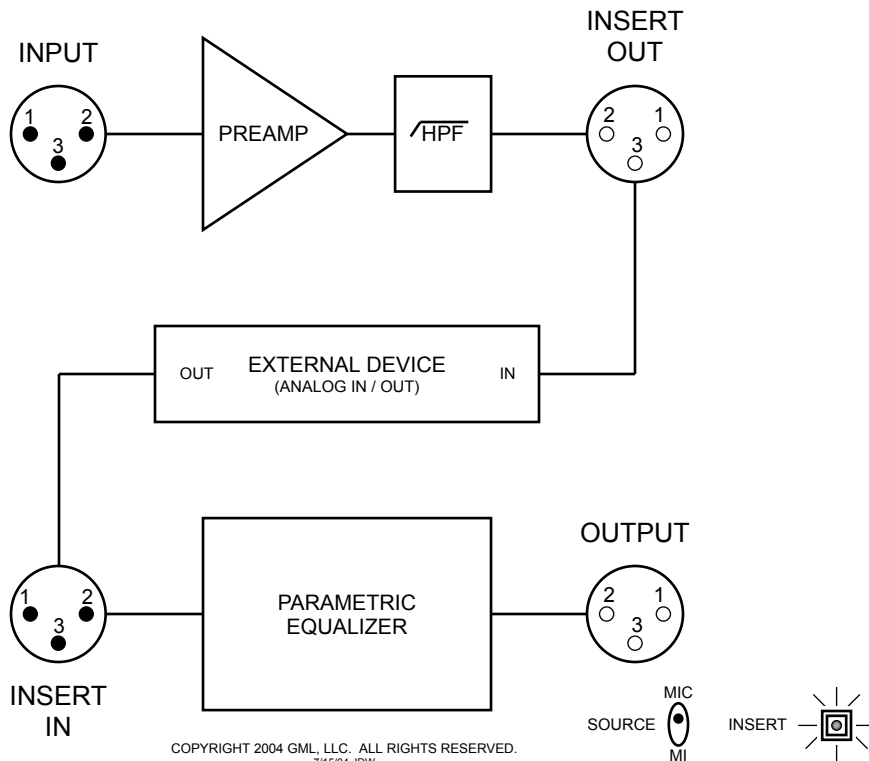

MODEL 2032 MICROPHONE PREAMPLIFIER / PARAMETRIC EQUALIZER

BLOCK DIAGRAM
All Routing Options

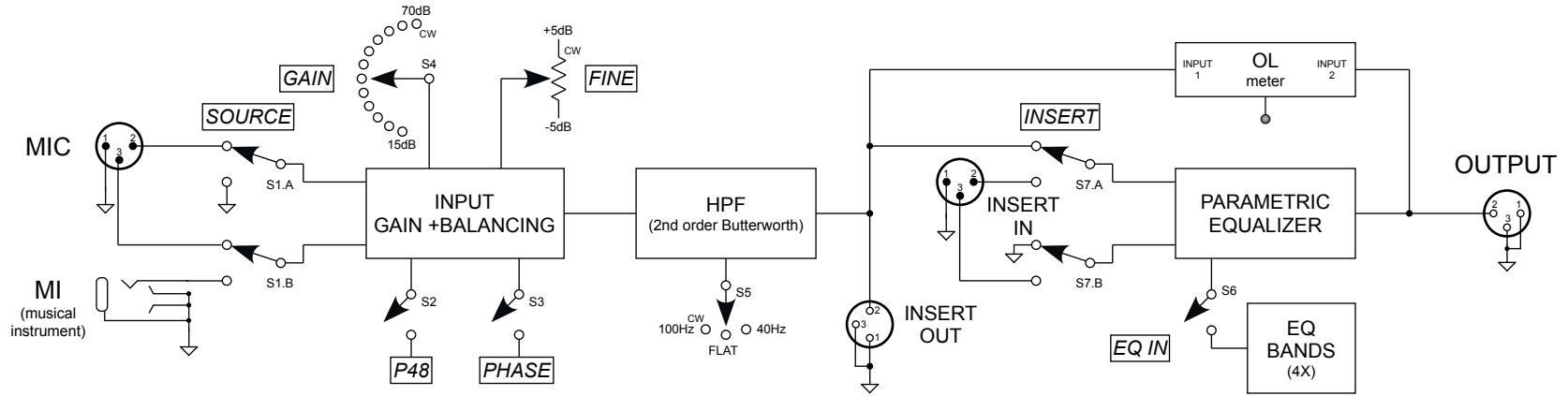

MODEL 2032 MICROPHONE PREAMPLIFIER / PARAMETRIC EQUALIZER

BLOCK DIAGRAM
Independent Operation

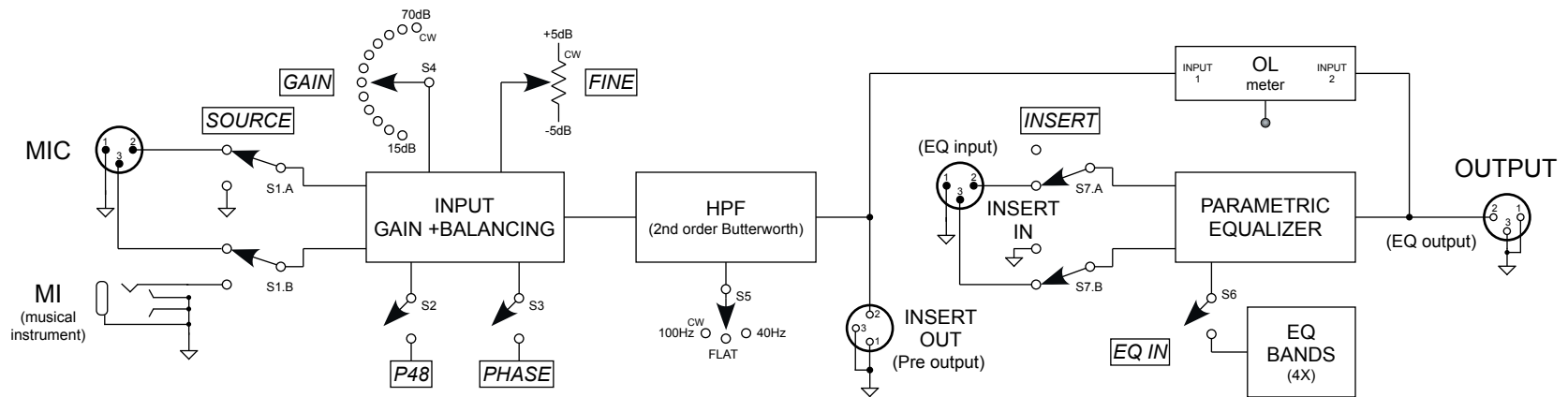

SOURCE SELECT P48 **GAIN** **FINE** **FILTER** high-pass **EQ IN**

MIC MI PHASE

40 Hz FLAT 100 Hz

OL

LOW **LOW-MID** **EQUALIZER** **HIGH-MID** **HIGH**

CUT 0 dB BOOST

SHELF kHz x100 kHz kHz kHz

POWER

GML MODEL 2032 MICROPHONE PREAMPLIFIER I PARAMETRIC EQUALIZER

CLIENT _____ PROJECT _____ DATE _____

TRACK (Pre) _____ ENGINEER _____ TRACK (EQ) _____

INSTRUMENT (Pre) _____ ASSISTANT _____ INSTRUMENT (EQ) _____

SOURCE SELECT P48 **GAIN** **FINE** **FILTER** high-pass **EQ IN**

MIC MI PHASE

40 Hz FLAT 100 Hz

OL

LOW **LOW-MID** **EQUALIZER** **HIGH-MID** **HIGH**

CUT 0 dB BOOST

SHELF kHz x100 kHz kHz kHz

POWER

GML MODEL 2032 MICROPHONE PREAMPLIFIER I PARAMETRIC EQUALIZER

CLIENT _____ PROJECT _____ DATE _____

TRACK (Pre) _____ ENGINEER _____ TRACK (EQ) _____

INSTRUMENT (Pre) _____ ASSISTANT _____ INSTRUMENT (EQ) _____

SOURCE SELECT P48 **GAIN** **FINE** **FILTER** high-pass **EQ IN**

MIC MI PHASE

40 Hz FLAT 100 Hz

OL

LOW **LOW-MID** **EQUALIZER** **HIGH-MID** **HIGH**

CUT 0 dB BOOST

SHELF kHz x100 kHz kHz kHz

POWER

GML MODEL 2032 MICROPHONE PREAMPLIFIER I PARAMETRIC EQUALIZER

CLIENT _____ PROJECT _____ DATE _____

TRACK (Pre) _____ ENGINEER _____ TRACK (EQ) _____

INSTRUMENT (Pre) _____ ASSISTANT _____ INSTRUMENT (EQ) _____

SOURCE SELECT P48 **GAIN** **FINE** **FILTER** high-pass **EQ IN**

MIC MI PHASE

40 Hz FLAT 100 Hz

OL

LOW **LOW-MID** **EQUALIZER** **HIGH-MID** **HIGH**

CUT 0 dB BOOST

SHELF kHz x100 kHz kHz kHz

POWER

GML MODEL 2032 MICROPHONE PREAMPLIFIER I PARAMETRIC EQUALIZER

CLIENT _____ PROJECT _____ DATE _____

TRACK (Pre) _____ ENGINEER _____ TRACK (EQ) _____

INSTRUMENT (Pre) _____ ASSISTANT _____ INSTRUMENT (EQ) _____